

LM5020 Evaluation Board

National Semiconductor
Application Note 1314
Grant Smith
February 2005



Introduction

The LM5020 evaluation board is designed to provide the design engineer with a fully functional non-isolated flyback power converter to evaluate the LM5020 controller.

The performance of the evaluation board is as follows:

- Input range: 30V to 75V (100V peak)
- Output voltage: 3.3V
- Output current: 0.2 to 4.5A
- Measured efficiency: 85% at 1.5A, 83% at 4.5A
- Board size: 1.25 x 2.5 x 0.5 inches
- Load Regulation: 1.5%
- Line Regulation: 0.1%
- Line UVLO, Current Limit

The printed circuit board consists of 2 layers of 2 ounce copper on FR4 material with a total thickness of 0.050 inches. Soldermask has been omitted from some areas to facilitate cooling. The unit is designed for continuous operation at rated load at < 40°C with normal convection cooling.

Theory of Operation

The flyback converter is an inductive based converter in which inductive energy is stored by applying a voltage across an inductor in a similar manner to that of a boost converter. Here the similarity ends. A second coupled winding of the inductor transfers the energy to a secondary side

rectifier after the voltage has been removed from the first winding. This allows the converter input and output grounds to be configured either isolated or non-isolated. There is also a voltage/current ratio change possible by altering the winding ratio between the first winding and the second winding. A semi-regulated auxiliary winding can also be provided.

The flyback transformer is actually a coupled inductor with multiple windings wound on a single core. For simplification, we will refer to the first, driven winding, as the primary and the main output winding as the secondary winding of the flyback transformer.

The transformer's primary inductance is typically made as large as is practical. However, the airgap necessary to store the cycle energy lowers the obtainable inductance. The higher the primary inductance, the less input ripple current will be generated and the less input filtering will be required.

As shown, the LM5020 directly drives a mosfet switch to apply voltage across the primary. When the switch turns off, the secondary applies a forward current to the output rectifier and charges the output capacitor. In applications where the input voltage is considerably higher than the output voltage, the turns ratio between primary and secondary will reflect the input/output voltage ratio and the duty cycle.

The LM5020 is a full-featured controller providing an internal start-up regulator, soft start, over-current and under-voltage lockout.

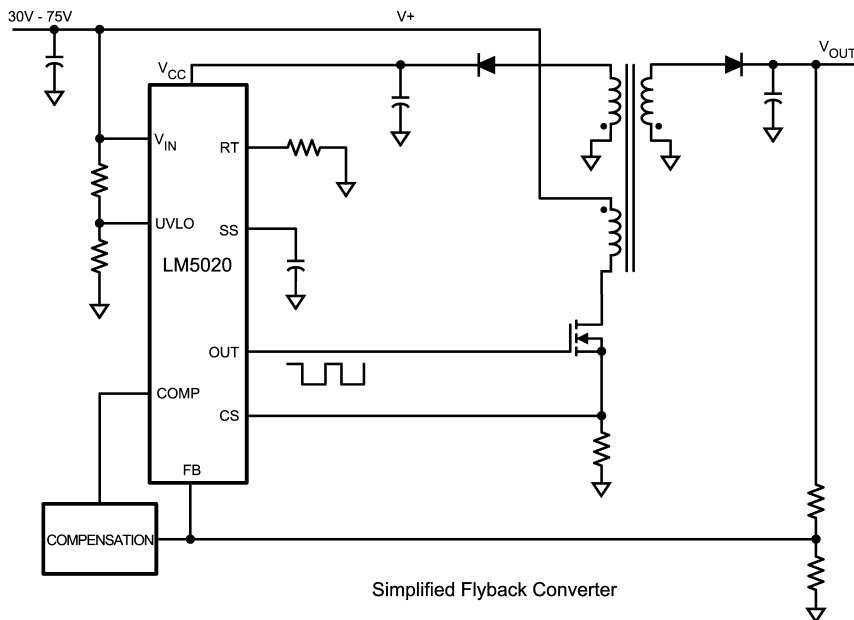

Powering and Loading Considerations

When applying power to the LM5020 evaluation board certain precautions should be followed. The LM5020 evaluation board is quite forgiving of load and input power variations. The possibility of shipping damage or infant failure is always a concern at first power-up.

Proper Connections

Be sure to choose the correct wire size when attaching the source supply and the load. Monitor the current into and out of the UUT. Monitor the voltages in and out directly at the terminals of the UUT. The voltage drop across the connecting wires will yield inaccurate measurements. For accurate efficiency measurements, these precautions are especially important.

Source Power

At low input line voltage (30V) the input current will be approximately 0.63A, while at high input line voltage the input current will be approximately 0.23. Therefore to fully test the LM5020 evaluation board a DC power supply capable of at least 75V and 1A is required. The power supply must have adjustments for both voltage and current. An accurate readout of output current is desirable since the current is not subject to loss in the cables as voltage is.

The power supply and cabling must present a low impedance to the UUT. Insufficient cabling or a high impedance power supply will cause droop during power supply application with the UUT inrush current. If large enough, this droop

will cause a chattering condition upon power up. This chattering condition is an interaction with the UUT undervoltage lockout, the cabling impedance and the inrush current.

Loading

An appropriate electronic load specified for operation down to 2.0V is desirable. The maximum load current is specified as 4.5A. Minimum load is specified at 5% or 0.23A. The resistance of a maximum load is 0.73 Ω (including cables). The resistance of a minimum load is 14.4 Ω .

Powering Up

Using the shutdown feature provided on the UUT will allow powering up the source supply initially with a low current level. It is suggested that the load be kept reasonably low during the first power up. Set the current limit of the source supply to provide about 1½ times the wattage of the load. As you remove the connection from the shutdown pin to ground, immediately check for 3.3 volts at the output. If more than a couple of seconds pass without seeing an output voltage, remove input power.

A quick efficiency check is the best way to confirm that the UUT is operating properly. If something is amiss you can be reasonably sure that it will affect the efficiency adversely. Few parameters can be incorrect in a switching power supply without creating additional losses and potentially damaging heat. An efficiency above 80% is expected.

After the unit is verified operationally, it can be powered up without use of the shutdown pin.

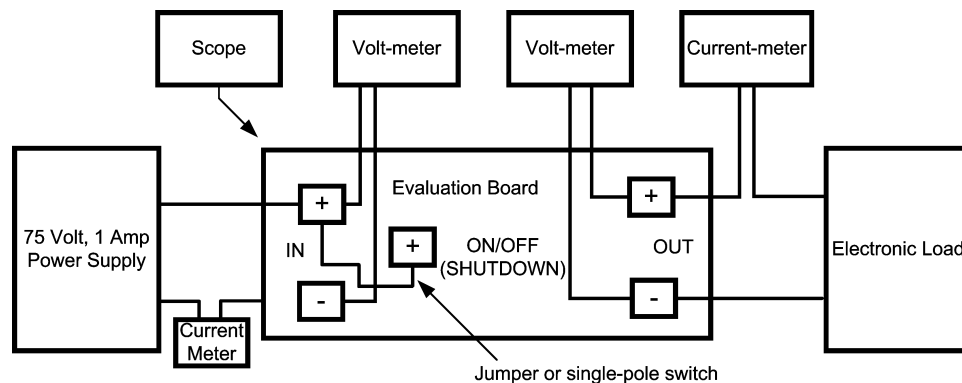

Typical Evaluation Setup

20095302

Performance Characteristics

TURN-ON WAVEFORMS

When applying power to the LM5020 evaluation board a certain sequence of events must occur. The soft-start feature allows for a minimal output voltage for a short time until the feedback loop can stabilize without overshoot. *Figure 1*, *Figure 2* and *Figure 3* show typical turn-on waveforms at no load, 5% load, and at full load. Input voltage, output voltage and output current are shown.

Figure 4 shows the initial ramp-up of the Vcc pin to 7.7 volts through the internal regulator. The auxiliary winding starts to supply a higher voltage as the output voltage rises. The resulting second ramp is shown following the soft-start delay. This sequence is nearly identical for all loads and input voltages.

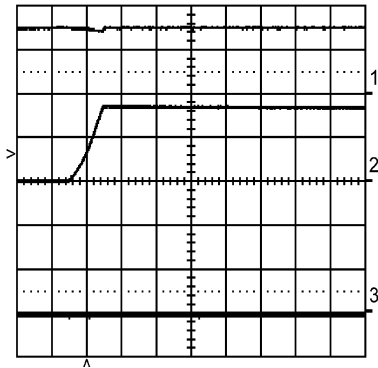

20095308

Trace 1: Input Voltage, at 30VDC.
Volts/div = 20.0V
Trace 2: Output Voltage, no load.
Volts/div = 2.0V
Trace 3: Output Current, no load.
Amps/div = 100mA
Horizontal Resolution = 1.0ms/div

FIGURE 1.

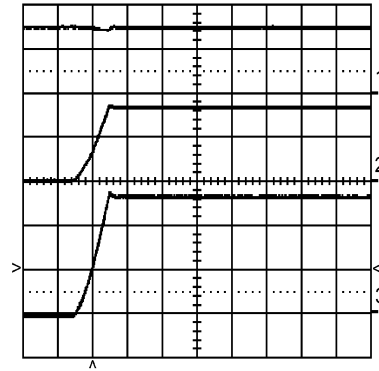

20095306

Trace 1: Input Voltage, at 30VDC.
Volts/div = 20.0V
Trace 2: Output Voltage, at 5% load.
Volts/div = 2.0V
Trace 3: Output Current, at 5% load.
Amps/div = 100mA
Horizontal Resolution = 1.0ms/div

FIGURE 2.

Performance Characteristics

(Continued)

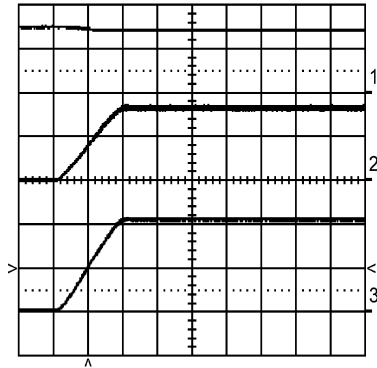

20095307

Trace 1: Input Voltage, at 30VDC.
Volts/div = 20.0V
Trace 2: Output Voltage, at full load.
Volts/div = 2.0V
Trace 3: Output Current, at full load.
Amps/div = 2.0A
Horizontal Resolution = 1.0ms/div

FIGURE 3.

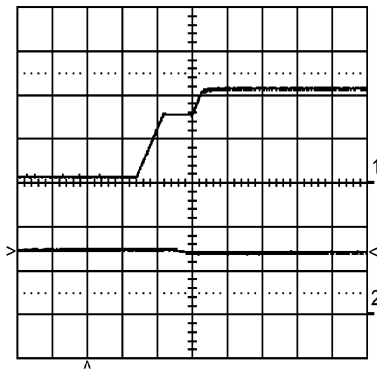

20095309

Trace 1: V_{CC} pin with $V_{IN} = 30VDC$, Load = 4.5A
Volts/div = 5.0V
Trace 2: V_{IN} approaching 30VDC
Volts/div = 20.0V
Horizontal Resolution = 2.0ms/div

FIGURE 4.

LOAD STEP RESPONSE

Figure 5 shows the load step response at $V_{in} = 30VDC$ for an instantaneous load change from 5% to full load. The input voltage, output voltage and output current are shown.

RIPPLE VOLTAGE AND RIPPLE CURRENT

Figure 6 shows the output ripple voltage, the output ripple current and the input ripple current relative to the LM5020 gate drive.

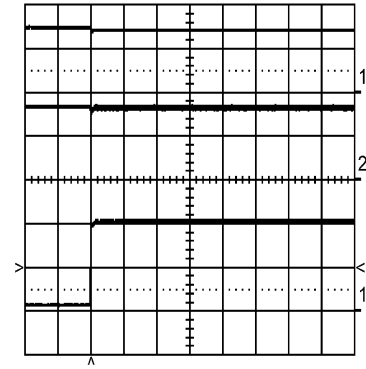

20095304

Trace 1: Input Voltage, at 30VDC
Volts/div = 20.0V
Trace 2: Output Voltage, at 3.3VDC
Volts/div = 2.0V
Trace 3: Load changing from 0.23A to 4.5A instantaneously
Amps/div = 2.0A
Horizontal Resolution = 1.0ms/div

FIGURE 5.

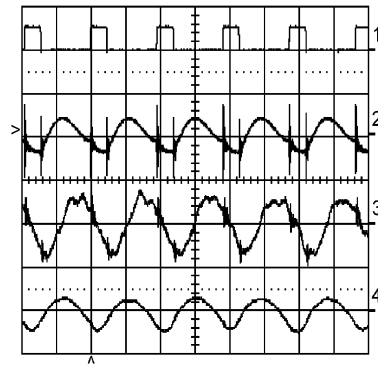

20095305

Trace 1: Q1 gate drive at $V_{in} = 48VDC$
Volts/div = 20.0V
Trace 2: Output ripple voltage
Volts/div = 100mV
Trace 3: Output ripple current
Amps/div = 20.0mA
Trace 4: Input ripple current
Amps/div = 100mA
Horizontal Resolution = 2.0 μ s/div

FIGURE 6.

Performance Characteristics

(Continued)

TRANSFORMER WAVEFORMS

Figure 7, Figure 8 and Figure 9 show typical waveforms at the junction of Q1 mosfet and the transformer primary winding. Also shown are typical waveforms at the junction of the transformer secondary and the output rectifier, D3. Figure 7 reflects an input voltage of 30VDC and a load of 4.5A. Figure 8 reflects an input voltage of 50VDC with the same load. Figure 9 reflects an input voltage of 75VDC, also at full load.

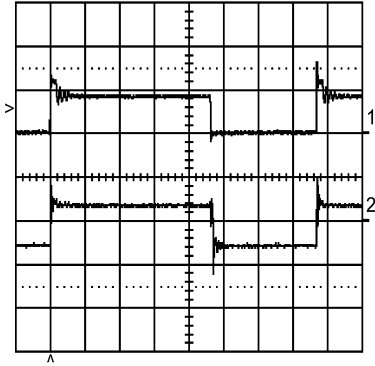

20095310

Trace 1: Drain of Q1 at Vin = 30VDC
 Volts/div = 50.0V
 Trace 2: Anode of D3
 Volts/div = 10.0V
 Horizontal Resolution = 0.5µs/div

FIGURE 7.

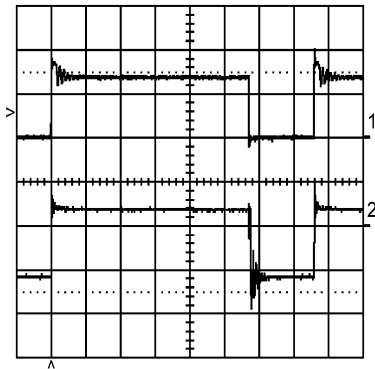

20095311

Trace 1: Drain of Q1 at Vin = 50VDC
 Volts/div = 50.0V
 Trace 2: Anode of D3
 Volts/div = 10.0V
 Horizontal Resolution = 0.5µs/div

FIGURE 8.

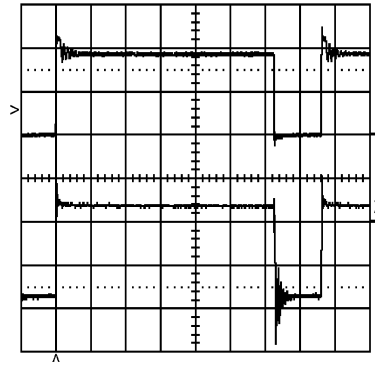

20095312

Trace 1: Drain of Q1 at Vin = 75VDC
 Volts/div = 50.0V
 Trace 2: Anode of D3
 Volts/div = 10.0V
 Horizontal Resolution = 0.5µs/div

FIGURE 9.

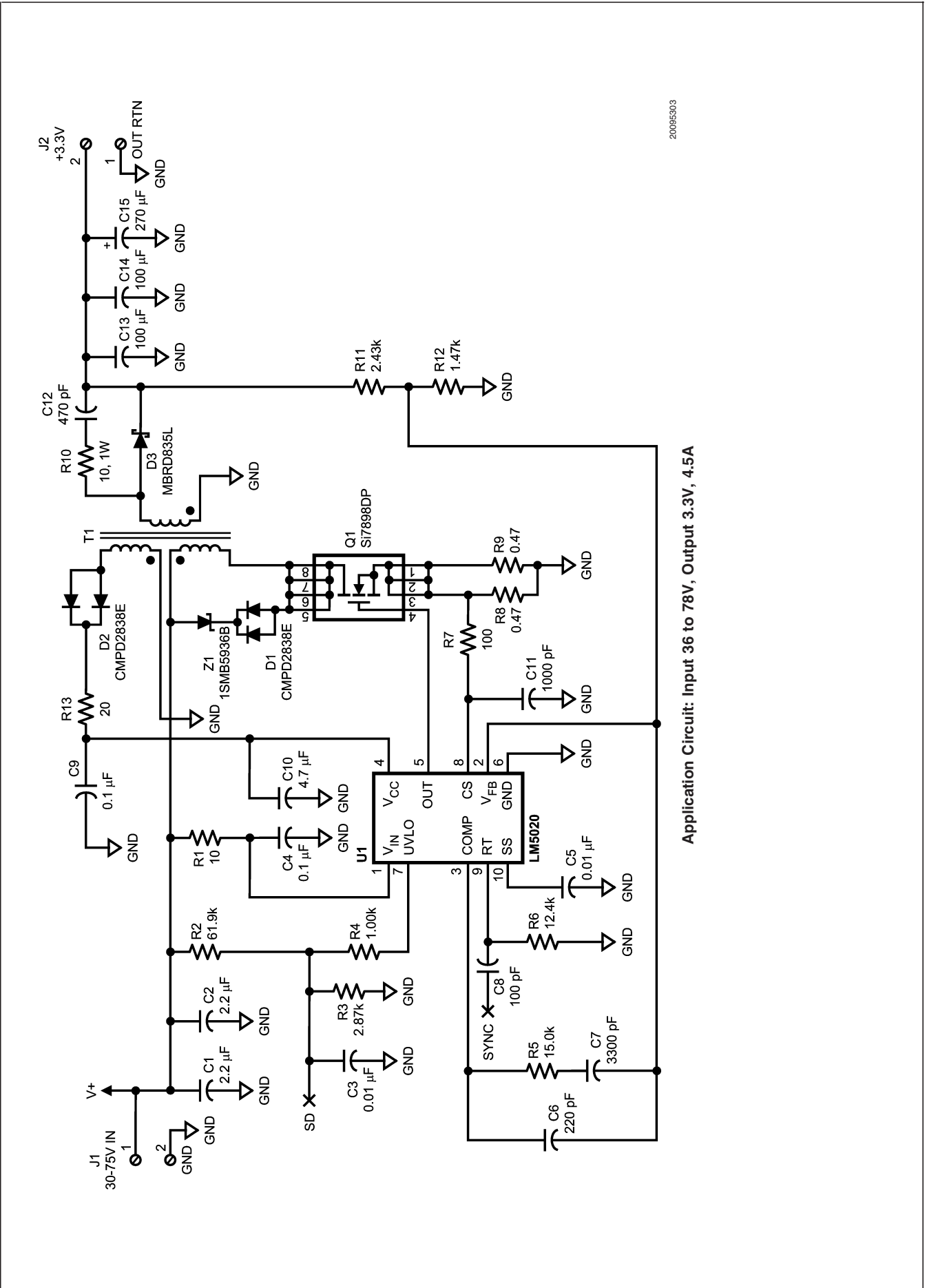

20065303

Application Circuit: Input 36 to 78V, Output 3.3V, 4.5A

Layout and Bill of Materials

The Bill of Materials is shown below and includes the manufacturer and part number. The layers of the printed circuit board are shown in top down order. View is from the top

down. Scale is approximately X2.0. The printed circuit board consists of 2 layers of 2 ounce copper on FR4 material with a total thickness of 0.050 inches.

Bill of Materials

Designator	Description	Manufacturer	Part Number
C1	2.2 μ F, 100V, CER, X7R, 1812	TDK	C4532X7R2A225M
C2	2.2 μ F, 100V, CER, X7R, 1812	TDK	C4532X7R2A225M
C3	0.01 μ F, 50V, CER, X7R, 0805	TDK	C2012X7R1H103K
C4	0.1 μ F, 100V, CER, X7R, 1206	TDK	C3216X7R2A104K
C5	0.01 μ F, 50V, CER, X7R, 0805	TDK	C2012X7R1H103K
C6	220pF, 50V, CER, COG, 0805	TDK	C2012COG1H221J
C7	3300pF, 50V, CER, COG, 0805	TDK	C2012COG1H332K
C8	100pF, 50V, CER, COG, 0805	TDK	C2012COG1H101J
C9	0.1 μ F, 50V, CER, X7R, 0805	TDK	C2012X7R1H104K
C10	4.7 μ F, 16V, CER, X7R, 1206	TDK	C3216X7R1C475K
C11	1000pF, 50V, CER, COG, 0805	TDK	C2012COG1H102J
C12	470pF, 50V, CER, COG, 0805	TDK	C2012COG1H471J
C13	100 μ F, 4V, CER, X7S, 1812	TDK	C4532X7S0G107M
C14	100 μ F, 4V, CER, X7S, 1812	TDK	C4532X7S0G107M
C15	270 μ F, 4V, ALUM ORG, 3018 PKG	KEMET	A700X277M0004AT
D1	DUAL, SIGNAL, COM CATH, SOT-23	CENTRAL SEMICONDUCTOR	CMPD2838E-NSA
D2	DUAL, SIGNAL, COM CATH, SOT-23	CENTRAL SEMICONDUCTOR	CMPD2838E-NSA
D3	SCHOTTKY RECT, 8A, 35V, D2PAK	ON SEMICONDUCTOR	MBRD835L
J1	TERMINAL BLOCK, SCREW, 2 POS	PHOENIX CONTACT	MKDS 1/2-3.81
J2	TERMINAL BLOCK, SCREW, 2 POS	PHOENIX CONTACT	MKDS 1/2-3.81
Q1	MOSFET, N-CH, 150V, 85m Ω , PWR SO8	VISHAY/SILICONIX	Si7898DP
R1	10.0 Ω , 1%, THICK FILM, 1206	VISHAY	CRCW120610R0J
R2	61.9K, 1%, THICK FILM, 1206	VISHAY	CRCW12066192F
R3	2.87K, 1%, THICK FILM, 0805	VISHAY	CRCW08052871F
R4	1.00K, 1%, THICK FILM, 0805	VISHAY	CRCW08051001F
R5	15.0K, 1%, THICK FILM, 0805	VISHAY	CRCW08051502F
R6	12.4K, 1%, THICK FILM, 0805	VISHAY	CRCW08051242F
R7	100 Ω , 1%, THICK FILM, 0805	VISHAY	CRCW08051000F
R8	0.47 Ω , 1%, THICK FILM, 1206	VISHAY	CRCW12060R47F
R9	0.47 Ω , 1%, THICK FILM, 1206	VISHAY	CRCW12060R47F
R10	10.0 Ω , 1%, 1W, THICK FILM, 2512	VISHAY	CRCW251210R0J
R11	2.43K, 1%, THICK FILM, 0805	VISHAY	CRCW08052431F
R12	1.47K, 1%, THICK FILM, 0805	VISHAY	CRCW08051471F
R13	20.0 Ω , 1%, THICK FILM, 0805	VISHAY	CRCW080520R0F
SD	TERMINAL, SMALL TEST POINT	KEYSTONE	5002
SYNC	TERMINAL, SMALL TEST POINT	KEYSTONE	5002
T1	TRANSFORMER, FLYBACK, EFD20	COILCRAFT	B0695-A
OR T1	TRANSFORMER, FLYBACK, EFD20	PULSE	PA0751
U1	CONTROLLER, SINGLE OUT, PWM, MSOP10	NATIONAL SEMICONDUCTOR	LM5020-1MM
Z1	ZENER, 30V, SMB PKG.	ON SEMICONDUCTOR	1SMB5936B

PCB Layouts

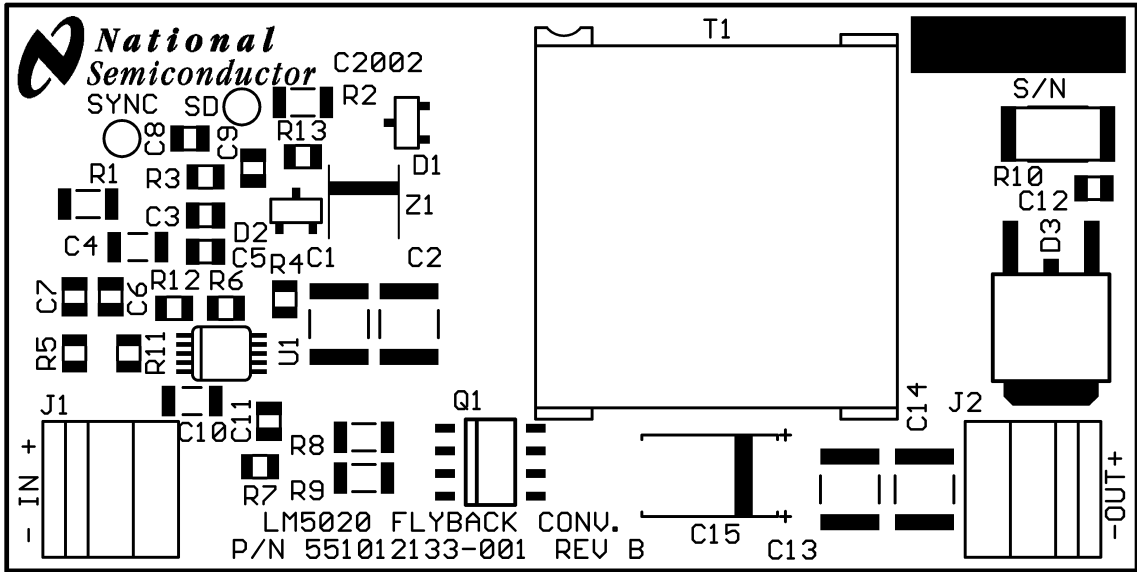

TOP SILKSCREEN

20095313

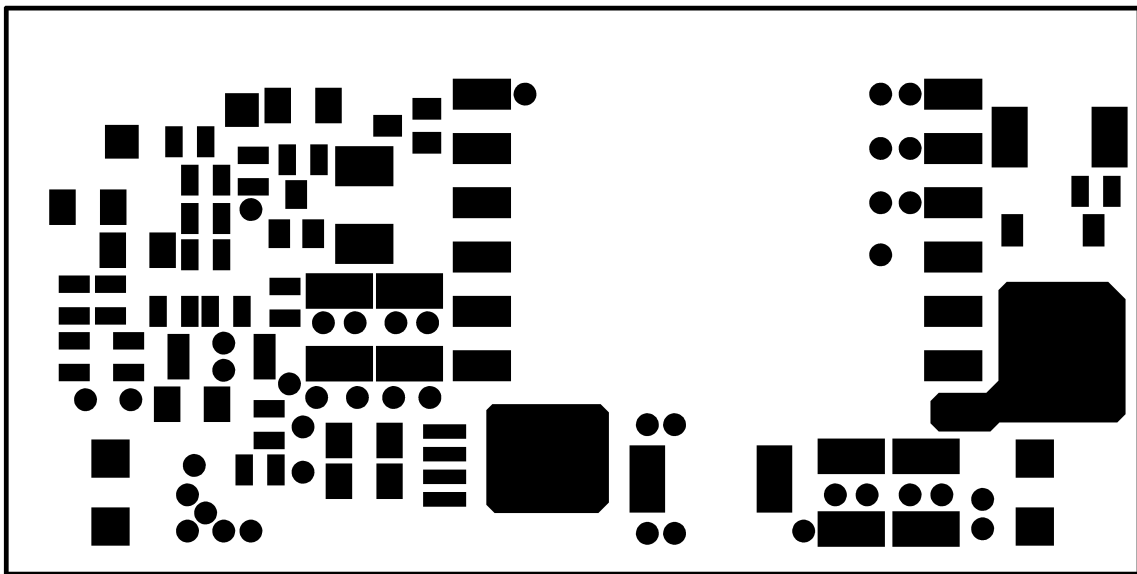

TOP SOLDERMASK

20095314

PCB Layouts (Continued)

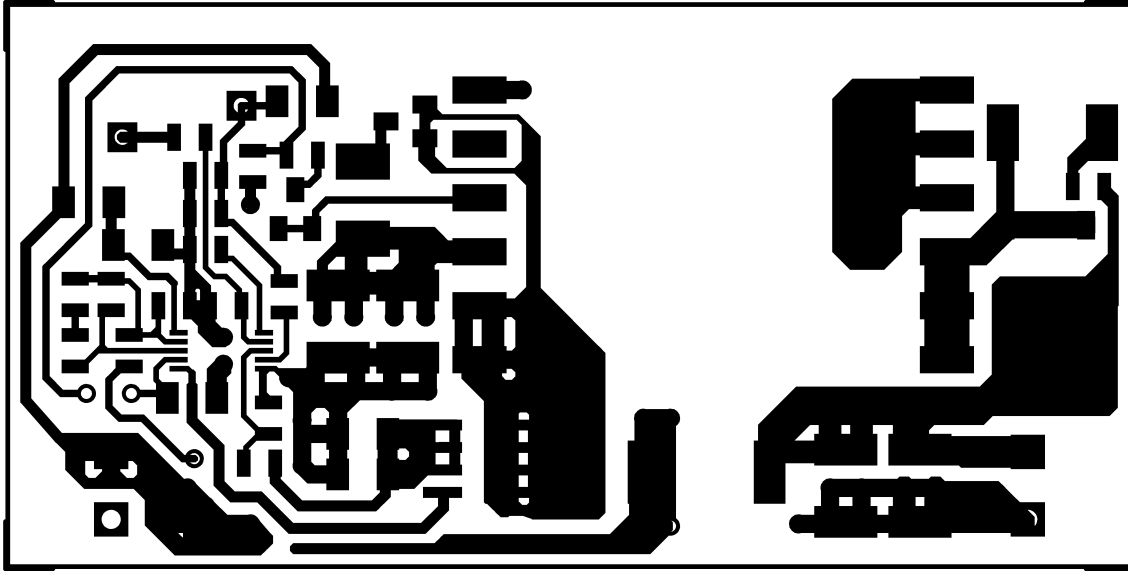

TOP COPPER

20095315

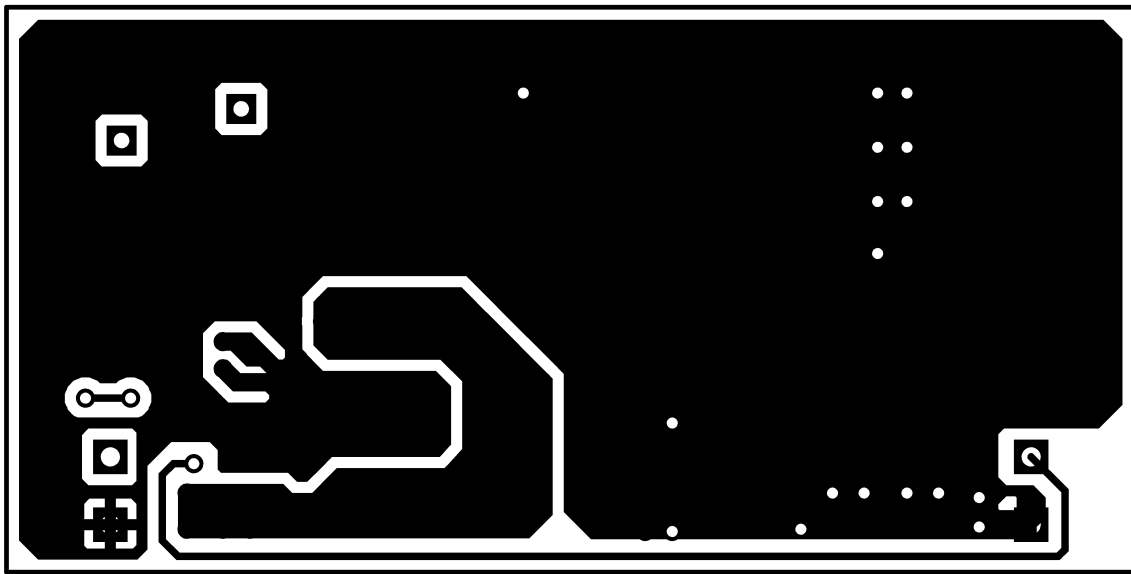

BOTTOM COPPER

20095316

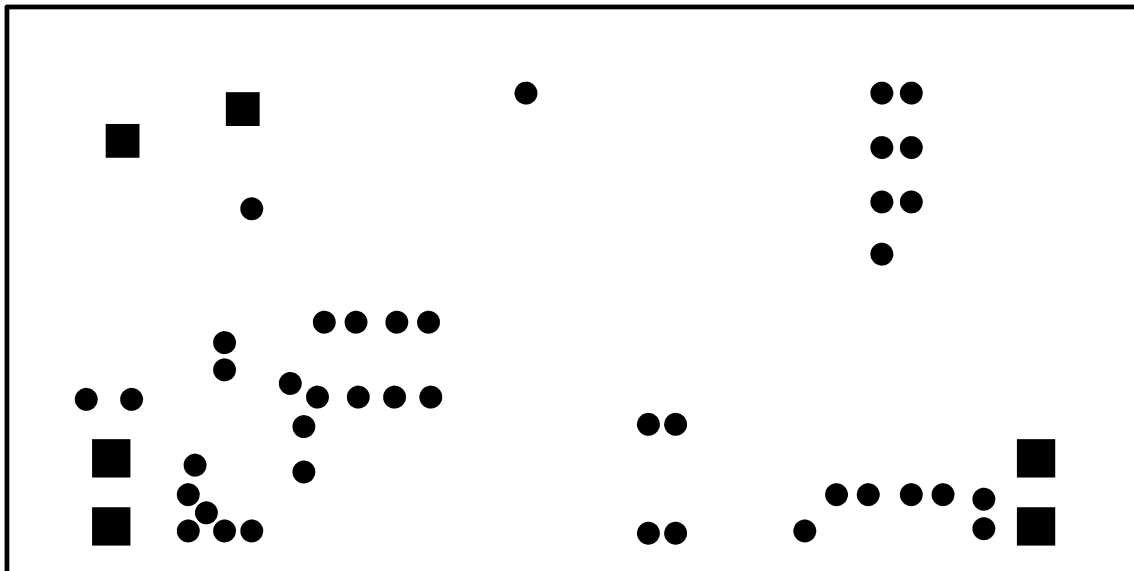
PCB Layouts (Continued)**BOTTOM SOLDERMASK**

20095317

National does not assume any responsibility for use of any circuitry described, no circuit patent licenses are implied and National reserves the right at any time without notice to change said circuitry and specifications.

For the most current product information visit us at www.national.com.

LIFE SUPPORT POLICY

NATIONAL'S PRODUCTS ARE NOT AUTHORIZED FOR USE AS CRITICAL COMPONENTS IN LIFE SUPPORT DEVICES OR SYSTEMS WITHOUT THE EXPRESS WRITTEN APPROVAL OF THE PRESIDENT AND GENERAL COUNSEL OF NATIONAL SEMICONDUCTOR CORPORATION. As used herein:

1. Life support devices or systems are devices or systems which, (a) are intended for surgical implant into the body, or (b) support or sustain life, and whose failure to perform when properly used in accordance with instructions for use provided in the labeling, can be reasonably expected to result in a significant injury to the user.
2. A critical component is any component of a life support device or system whose failure to perform can be reasonably expected to cause the failure of the life support device or system, or to affect its safety or effectiveness.

BANNED SUBSTANCE COMPLIANCE

National Semiconductor manufactures products and uses packing materials that meet the provisions of the Customer Products Stewardship Specification (CSP-9-111C2) and the Banned Substances and Materials of Interest Specification (CSP-9-111S2) and contain no "Banned Substances" as defined in CSP-9-111S2.



National Semiconductor
Americas Customer
Support Center
Email: new.feedback@nsc.com
Tel: 1-800-272-9959

www.national.com

National Semiconductor
Europe Customer Support Center
Fax: +49 (0) 180-530 85 86
Email: europa.support@nsc.com
Deutsch Tel: +49 (0) 69 9508 6208
English Tel: +44 (0) 870 24 0 2171
Français Tel: +33 (0) 1 41 91 8790

National Semiconductor
Asia Pacific Customer
Support Center
Email: ap.support@nsc.com

National Semiconductor
Japan Customer Support Center
Fax: 81-3-5639-7507
Email: jpn.feedback@nsc.com
Tel: 81-3-5639-7560